

# COMPLEMENTARY SOLUTIONS FOR PLASTIC INJECTION INDUSTRY

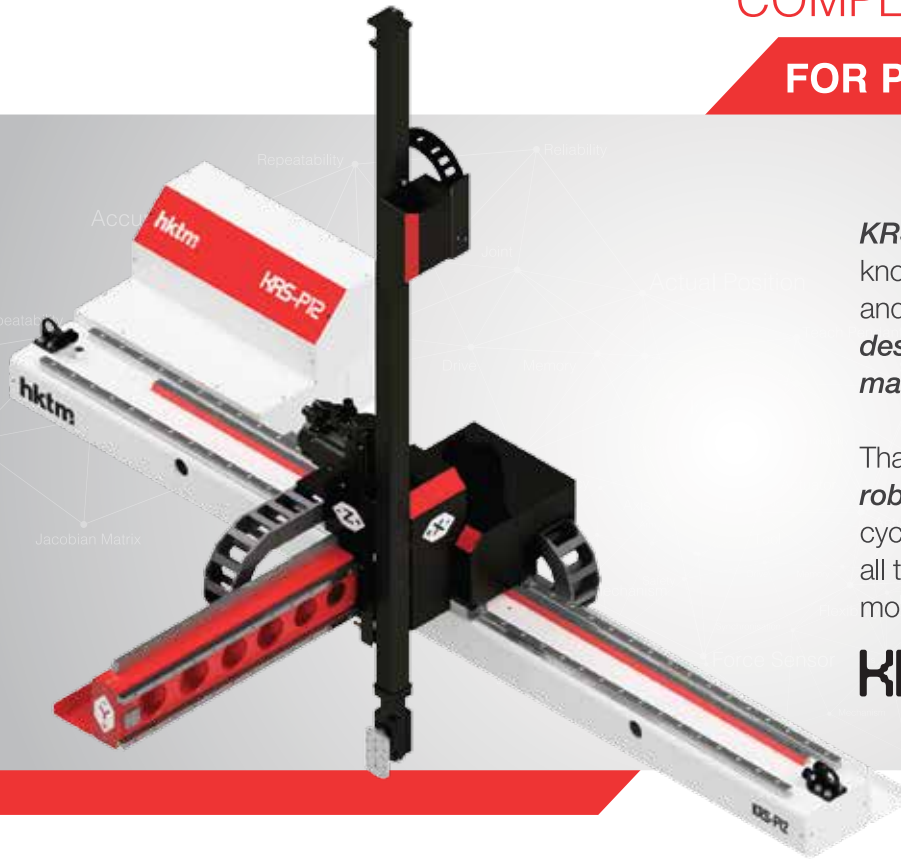

**KRS series robots**, together with the knowledge of HKTm, experience of 20 years and advanced technology, **have been designed for plastic injection molding machines**.

Thanks to their proven software, **KRS series robots** minimize the impact of robots on total cycle time by moving in synchronization with all the movements of your injection molding machine.

## KRS P12 CNC ROBOT

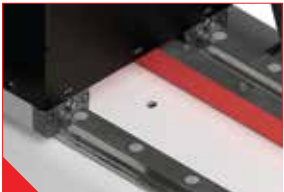

### Optimized Drive and Guiding System

A fast, precise and silent operating motion system thanks to the drive and guiding system optimized for operating at high speeds and accelerations.



### Fixed X Axis Design

Thanks to fixed X axis design, there are no moving parts behind the mounting plate.

Fixed X axis design creates free space for obstacles which may be present on the machine like building beams platforms, air ducts, etc.



### Integrated Control Panel

The control panel enables external I/O module's electrical connections to be made by bus cable and also enables external equipment to be controller directly. Custom design control panel, which is mounted on horizontal axis, saves space in the plant.



### Smart Vibration Control

Thanks to positioning speed optimization, vibration caused by external impacts is minimized actively.



### User-Friendly Interface

Quick installation, easy learning and practical use thanks to the interface and simple command sets. Independent programming feature for integrated maintenance period monitoring and robot operations.



### Integrated Line Filter

Standard EMC filter on the robot helps avoiding the failures caused by interference.

It minimizes the interference by responding to them and makes a more secure process possible.

Thanks to the dynamic servo motors, high precision linear movement components of **Bosch Rexroth** and engineering, **KRS series robots** are able to keep their pace and positions for each cycle at **pick and place, insert placement and quality control applications.**

With their internationally accepted software base, **they complete the machine** as they can be integrated accurately and easily into all plastic injection molding machines and applications.

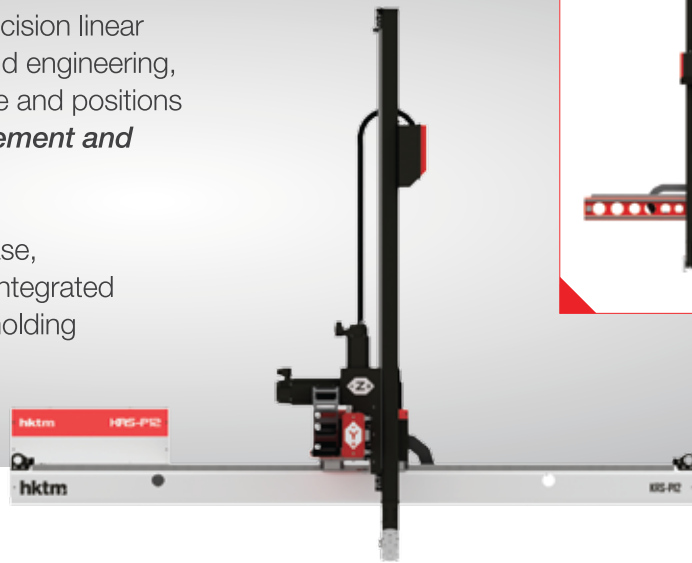

### Compact design

- Small footprint on machine thanks to the compact design
- Additional free space thanks to the control panel located on main axis

### Powerful and Dynamic Structure

- High rigidity and high precision thanks to steel profile axles
- Specially optimized drive and guiding system provides high speed and acceleration

### Easy Control

- Integration with all injection molding machines via Euromap interface (12 or 67)
- I/O support for robot arm equipment
- High quality servo motors and high precision linear movement components (Bosch Rexroth) for all axes
- High speed communication with axes via EtherCAT protocols

### User Interface

- 7" wide large screen and user-friendly interface
- Easy control and maximum usage efficiency with KeTop T70 user panel

### Options

- A secondary "Y" axis option for molds more than one platen
- Telescopic vertical axis option

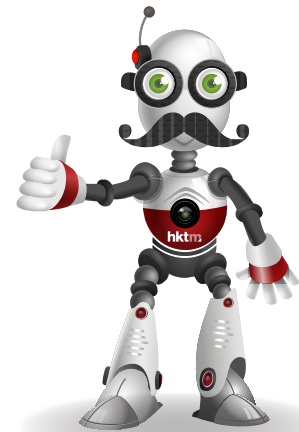

**completes your machine**

Models	Payload (kg)	Pick and Place X Axis (mm)	Horizontal Stroke Z Axis (mm)	Vertical Stroke Y Axis (mm)	Suitable Machine Tonnage (tonnes)
KRS-P12	12	440/540/640	940-3440 *	600/800/1000/1300	28-600
KRS-P12	15	440/540	940-3440 *	600/800/1000/1300	28-600

\* It can be increased by 500 mm and its multiples

\*\* Contact your customer representative for custom strokes.